

# 886 Facility Post

## with Standard Width Webbing

Perfect for indoor and outdoor use. Features a heavy duty base with easy carry handles. Ideal for health and safety applications.

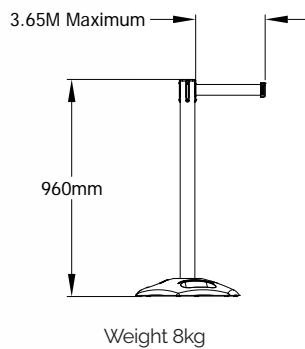
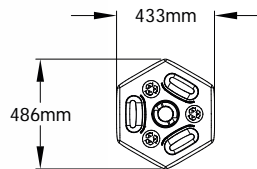
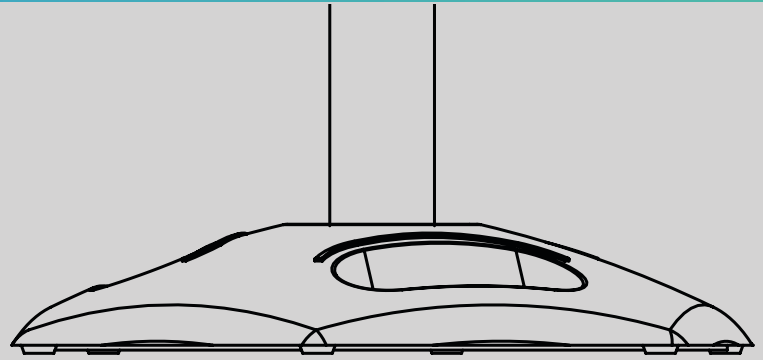

### Features & Benefits

- The facility post features a lightweight plastic post that screw fixes into a recycled rubber heavy duty base.
- The post and base can be quickly and easily dismantled for easy storage and transportation.
- The robust base can be walked or driven over and it will still retain its shape and function.
- Ideal for indoor and outdoor use, but shouldn't be permanently placed outside.
- The safest barrier on the market – our cassettes have a unique braking system for slower webbing retraction.

### Product Specification

- Plastic post available in 4 UV stable colours.
- Black recycled rubber base with easy carry handles, which allows for the post to be easily screwed into place.
- Shipped flat packed with no tools required.
- Available with any Tensator® standard (50mm) webbing options.
- Modular webbing cassette – all cassettes come as standard with our four-point anti-tamper webbing connectivity. This allows you to connect other Tensabarrier® products to the receiver splines on the cassette head.
- Compatible with all Tensabarrier® accessories including our range of post top signage.
- Available to buy in a twin pack.

### Applications

- Eliminate unsafe working conditions by clearly defining routes.
- Restrict access to dangerous areas.
- Use to identify hazards before they cause harm.
- Ideal for warehouses, industrial and maintenance areas.
- Indoor and outdoor use.

### Product Configuration

#### Base Options



Heavy Duty Base

#### Post Finishes



Four plastic finishes available

#### Webbing Options



Standard Webbing   Dual Line   Wide Webbing

50mm width   50mm width (each line)   150mm width

#### Webbing Lengths



50mm width   50mm width   150mm width

#### Webbing Designs



Range of colours, designs and custom options

#### Tape End Options



Six tape end options available

MILTON KEYNES  
+44 1908 684 600

NEW YORK  
+1 631 666 0336

DUBAI  
+971 4 2997 228

PARIS  
+33 1 43 09 85 00

FRANKFURT  
+49 69 3003 89 010

WROCLAW  
+48 71 359 3800